

**Ensign
Equipment
Inc.**

Stationary *Vertical Auger* Mixers

The Stationary Vertical Auger Mixer is designed to economically mix free flowing bulk solid materials. Its heavy duty auger lifts the material up from the bottom of the hopper and disperses it around the top. Stationary Mixers comes in sizes ranging from 30 to 1200 cu.ft. with a variety of fill and discharge options.

We have introduced many new features to this style of mixer. We have installed an inverted bottom sleeve bearing that centers the auger while eliminating the possibility of grease contamination of your material. We use interlocking safety switches to make the unit safer to operate and our bottom discharge rack and pinion slide gate has made jammed gates a thing of the past.

Our extended legs option would allow you to place the mixer high enough to gravity discharge into gaylords. The optional auger discharge would deliver your mixed material to a machine or storage vessel or Vacuum Discharge would enable you to deliver your mixed material directly into your vacuum system.



**72" Dia. Mixer with Dumper
Infeed and Auger Discharge**

We can adapt these mixers to your particular needs and can custom build them to fit any situation.

See back page for additional specifications.

All Ensign Equipment Inc. products carry a TWO YEAR warranty covering defects in manufacture, workmanship and components.

Ensign Equipment Inc.

12523 Superior Court
Holland, MI 49424
ensigneq.com

Phone: 616-738-9000
Fax: 616-738-9001
Toll Free: 800-753-8947
sales@ensigneq.com

Stationary Vertical Auger Mixers Specifications

48" Diameter Mixers

Model #	Capacity	Vert. Side
61-4800	30 cu. ft.	22"
61-4810	40 cu. ft.	32"
61-4820	50 cu. ft.	42"

- Auger Size - 6" OD Industrial
- Motor Size - 3-5 H.P., 3ph.
- Auger Speed - 375 RPM
- Ratio of Belt Drive - 4.5 :1
- Slide Gate Size - 8"
- Cone Capacity - 14 cu. ft.
- Capacity Per Vert. Ft. - 12 cu. ft.

60" Diameter Mixers

Model #	Capacity	Vert. Side
61-6100	75 cu. ft.	36"
61-6110	94 cu. ft.	48"
61-6120	113 cu. ft.	60"

- Auger Size - 9" OD Industrial
- Motor Size - 7.5-10 H.P., 3ph.
- Auger Speed - 345 RPM
- Ratio of Belt Drive - 5 :1
- Slide Gate Size - 12"
- Cone Capacity - 27 cu. ft.
- Capacity Per Vert. Ft. - 19 cu. ft.

72" Diameter Mixers

Model #	Capacity	Vert. Side
61-7200	143 cu. ft.	48"
61-7210	171 cu. ft.	60"
61-7220	200 cu. ft.	72"

- Auger Size - 12" OD Industrial
- Motor Size - 10-15 H.P., 3ph.
- Auger Speed - 287 RPM
- Ratio of Belt Drive - 6 :1
- Slide Gate Size - 14"
- Cone Capacity - 47 cu. ft.
- Capacity Per Vert. Ft. - 28 cu. ft.

90" Diameter Mixers

Model #	Capacity	Vert. Side
61-9000	250 cu. ft.	48"
61-9010	335 cu. ft.	72"
61-9020	425 cu. ft.	96"

- Auger Size - 14" OD Industrial
- Motor Size - 20-25 H.P., 3ph.
- Auger Speed - 287 RPM
- Ratio of Belt Drive - 6 :1
- Slide Gate Size - 16"
- Cone Capacity - 95 cu. ft.
- Capacity Per Vert. Ft. - 44 cu. ft.

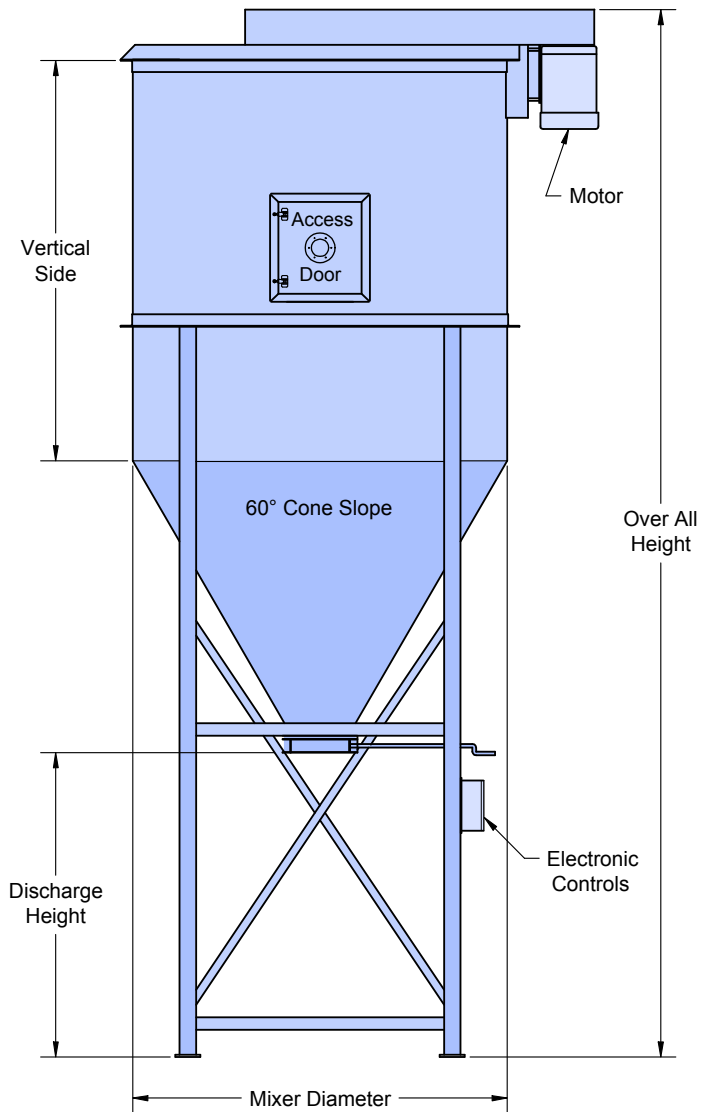

Features & Options

	48" Dia.	61" Dia.	72" Dia.	90" Dia.
Start-Stop Controls -----	Std.	Std.	Std.	Std.
Bolt Down Feet -----	Std.	Std.	Std.	Std.
Rack & Pinion Slide Gate----	Std.	Std.	Std.	Std.
Top Access Hatch -----	Std.	Std.	Option	Option
Side Access Door -----	Option	Option	Std.	Std.
Loader Mounting Pattern ----	Option	Option	Std.	Std.
Side Mount Discharge Gate -	Option	Option	Option	Option
Dumper Fill Chute -----	Option	Option	Option	Option
View Windows -----	Option	Option	Option	Option
Extended Legs -----	Option	Option	Option	Option
Vacuum Discharge -----	Option	Option	Option	Option

Ensign Equipment Inc.

12523 Superior Court
Holland, MI 49424
ensigneq.com

Phone: 616-738-9000
Fax: 616-738-9001
Toll Free: 800-753-8947
sales@ensigneq.com