

**Ensign
Equipment
Inc.**

Premier **Hydraulic Box Dumper**

The Premier Hydraulic Box Dumper is designed and built for continuous operation. It features 2" piloted roller bearings at the main pivot and bronze sleeve bearings at the top cylinder mounts. We use a proven 1.5 h.p. hydraulic package with easy to service components and a separate oil reservoir.

Designed for increased safety, this unit has solid side panels on the frame and a wider clearance between the frame and bucket to eliminate pinch points. The unit can be stopped anywhere in the up and down cycle simply by releasing the push button control.

Our standard units all have 2500# lift capacity and a gravity return. Units are powered by a pair of 2" bore, 2" rod, ram style cylinder. Special dust control and other hooded units use cylinders with a 3" bore and are powered on both the up and down cycles.



See back page for additional specifications.

All Ensign Equipment Inc. products carry a TWO YEAR warranty covering defects in manufacture, workmanship and components. Also all STANDARD products are covered by the Ensign Advantage, a 30 day trial period guaranteeing customer satisfaction!

Ensign Equipment Inc.

12523 Superior Court
Holland, MI 49424
ensigneq.com

Phone: 616-738-9000
Fax: 616-738-9001
Toll Free: 800-753-8947
sales@ensigneq.com

Premier Hydraulic Dumper

Standard Features:

- Bucket Rotation 135 deg.
- Motor 1.5 h.p.
- NEMA 12 Electrical Enclosure
- Hydraulic Cylinders w/ 24" stroke, 2" bore, 2" rod
- Adjustable Retaining Bar 32" to 48"
- Up Cycle Completion, Limit Switch
- Down Cycle Flow Control Valve
- Cycle Time- 30 sec. Up, 15 sec. Down
- Replaceable Pivot Bearings
- Ensign Blue Epoxy

Optional Features:

- Velocity fuse, (catches bucket in case of hydraulic rupture)
- Gaylord Entry Guides
- Custom Size and Shape Buckets
- Dust Hood with Discharge Hatch
- Dust Containment Doors on Bucket
- Dumper Stands 12" to 72"
- Floor Grate in Bucket
- Double Acting Hydraulics
- Explosion Proof Electrical
- Stainless Steel Chute Liner
- Stainless Steel Construction
- Custom Paints and Matching Colors

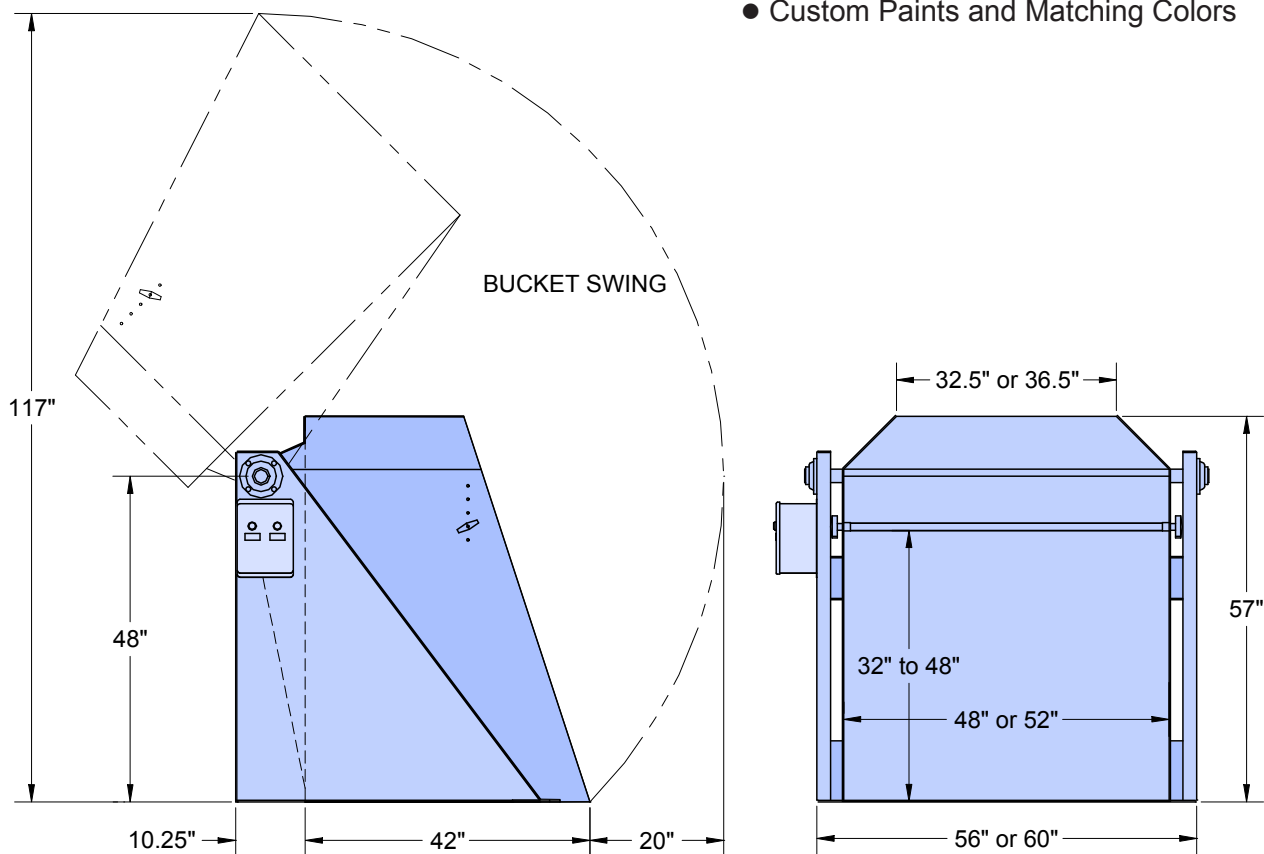

Model No.	Description
35-2500	Premier Dumper, Rear Load, 2500 lbs, Cap., 3 Phase, 48" Wide Bucket
35-2550	Premier Dumper, Rear Load, 2500 lbs. Cap., Single Phase, 48" Wide Bucket
35-5200	Premier Dumper, Rear Load, 2500 lbs. Cap., 3 Phase, 52" Wide Bucket
35-5250	Premier Dumper, Rear Load, 2500 lbs. Cap., Single Phase, 52" Wide Bucket

Ensign Equipment Inc.

12523 Superior Court
Holland, MI 49424
ensigneq.com

Phone: 616-738-9000
Fax: 616-738-9001
Toll Free: 800-753-8947
sales@ensigneq.com