

**Ensign
Equipment
Inc.**

Portable *Vertical Auger* Batch Mixers

The Portable Batch Mixer is designed to economically mix free flowing bulk solid materials. Its heavy duty 6" auger lifts the material up from the bottom of the hopper and disperses it around the top. Portable Batch Mixers comes in sizes ranging from 10 to 60 cu.ft. with a variety of fill and discharge options.

We have introduced many new features to this style of mixer. We have installed an inverted bottom sleeve bearing that prevents the auger from contacting the auger tube. Our internal safety cover switches have made the unit safer to operate and our bottom discharge roller slide gate has made jammed slide gates a thing of the past.

The 44" square leg pattern will fit Portable Storage Bins and Power Hoppers as well as a variety of mixer discharge stands. Our Gravity Discharge Stand will allow you to place the mixer high enough to gravity discharge into gaylords. The auger discharge stands will deliver your mixed material to a machine or a storage vessel and the Vacuum Discharge Stand will enable you to deliver your mixed material directly into your vacuum system.



We can adapt these mixers to your particular needs and we can custom build them to fit any situation.

See back page for additional specifications.

All Ensign Equipment Inc. products carry a TWO YEAR warranty covering defects in manufacture, workmanship and components. Also all STANDARD products are covered by the Ensign Advantage, a 30 day trial period guaranteeing customer satisfaction!

Ensign Equipment Inc.

12523 Superior Court
Holland, MI 49424
ensigneq.com

Phone: 616-738-9000
Fax: 616-738-9001
Toll Free: 800-753-8947
sales@ensigneq.com

Portable Batch Mixers

Standard Features:

- Double Hinged Covers
- 6" OD Agitator Auger
- Roller Slide Gate
- Two Way Fork Channels
- 14 ga Hopper, w 10 ga Legs
- Push Button Start Stop
- 30 min. Cycle Timer
- NEMA 12 Electrical Enclosure
- Safety Shut Off Switches in Covers
- Motor, TEFC 3/4 to 2 h.p.
- Direct Gear Drive
- Ensign Blue Epoxy

Optional Features:

- Easy Clean Hinged Auger Tube
- Vacuum Loader Mounting Hole in Cover
- Dump Chute Adaptor
- Auger Inlet Adaptor
- 304 SS Hopper and Auger Assembly
- Gaylord Discharge Stand
- Auger Discharge Stand
- Vacuum Discharge Stand
- Custom Paints and Matching Colors

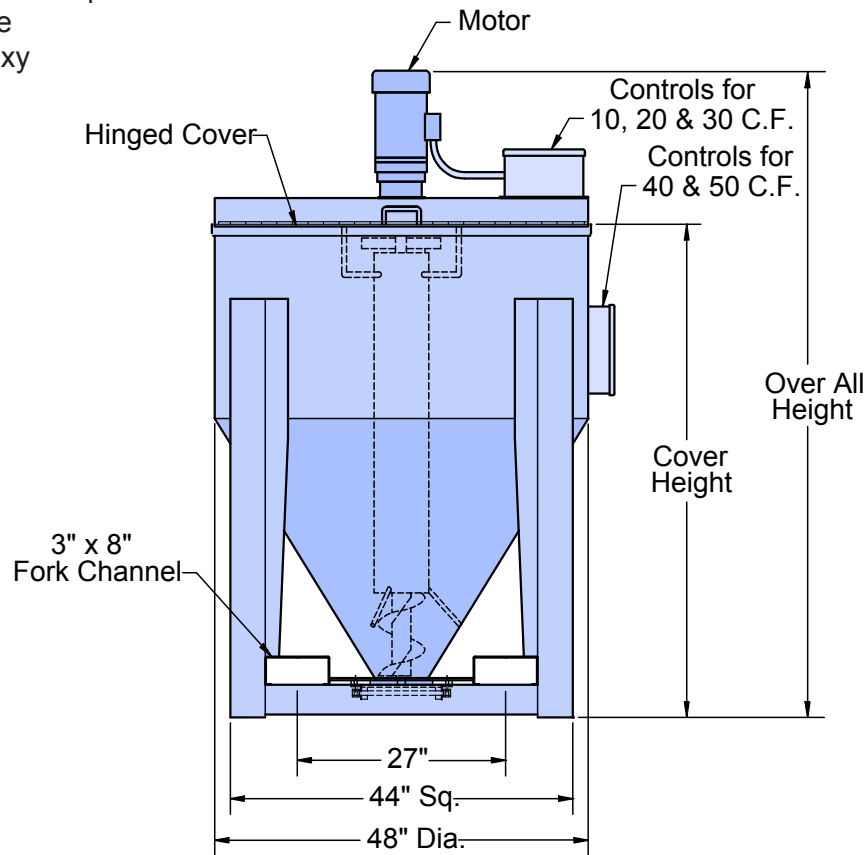

Model No. 1 ph. Elec.	Model No. 3 ph. Elec.	Description	Cover Height	Overall Height
60-1000	60-1200	Portable Batch Mixer, 10 cu. ft.	40.5"	60"
60-2000	60-2200	Portable Batch Mixer, 20 cu. ft.	46.5"	66"
60-3000	60-3200	Portable Batch Mixer, 30 cu. ft.	56.5"	76"
60-4000	60-4200	Portable Batch Mixer, 40 cu. ft.	66.5"	86"
60-5000	60-5200	Portable Batch Mixer, 50 cu. ft.	76.5"	96"

Ensign Equipment Inc.

12523 Superior Court
Holland, MI 49424
ensigneq.com

Phone: 616-738-9000
Fax: 616-738-9001
Toll Free: 800-753-8947
sales@ensigneq.com