

Ensign Equipment Inc.

Hydraulic Lift & Dump

The Hydraulic Lift & Dump is designed and built for continuous operation. It features 2" roller bearings at the main pivot and bronze sleeve bearings at the top cylinder mounts. We use a proven 2 hp hydraulic power unit with integral pump and oil reservoir.

Designed for increased safety, this unit has expanded metal side panels on the frame and a wider clearance between the frame and bucket to eliminate pinch points. The unit can be stopped anywhere in the up and down cycle simply by releasing the push button control.

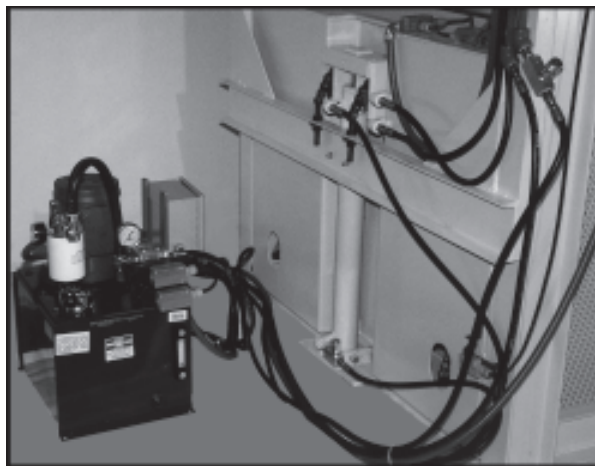

Hydraulic power unit with 10 foot hose.



Our standard units all have 2500# lift capacity with double acting hydraulics. Units are powered by a 3" mast cylinder and a pair of 2" bore, 1.5" rod dump cylinders. Special dust control hoods and other custom bucket designs are available options on these heavy duty units.

Ensign Equipment Inc.

12523 Superior Court
Holland, MI 49424
ensigneq.com

Phone: 616-738-9000
Fax: 616-738-9001
Toll Free: 800-753-8947
sales@ensigneq.com

Hydraulic Lift & Dump

Standard Features:

- Bucket Rotation 135 deg.
- Motor 2 hp
- NEMA 12 Electrical Enclosure
- Double Acting Hydraulics
- Lift Cylinder, 3" bore, 1.5" rod
- Dump Cylinders w/ 24" stroke, 2" bore, 1.5" rod
- Adjustable Retaining Bar 32" to 48"
- Up Cycle Completion, Limit Switch
- Down Cycle Flow Control Valves
- Cycle Time- 45 sec. Up, 45 sec. Down
- Velocity fuse, in Lift Cylinder
- Replaceable Pivot Bearings
- Ensign Blue Epoxy

Optional Features:

- Gaylord Entry Guides
- Custom Size and Shape Buckets
- Dust Hood with Discharge Hatch
- Dust Containment Doors on Bucket
- Floor Grate in Bucket
- Explosion Proof Electrical
- Stainless Steel Chute Liner
- Stainless Steel Construction
- Custom Paints and Matching Colors

All Ensign Equipment Inc. products carry a TWO YEAR warranty covering defects in manufacture, workmanship and components.

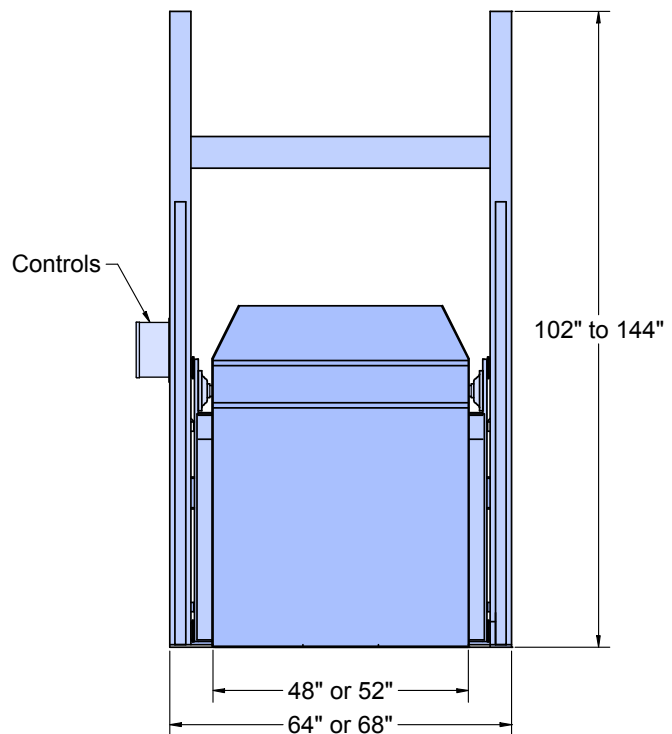
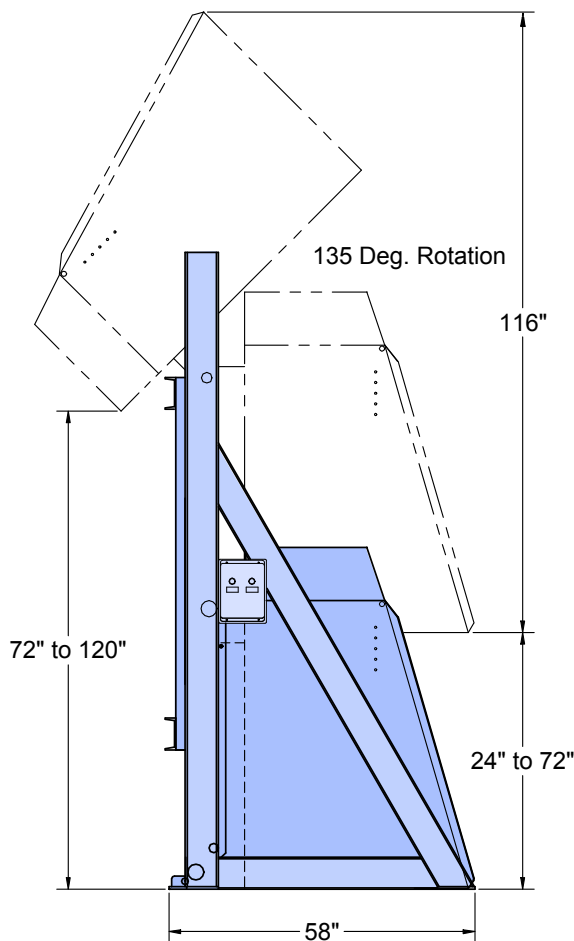

Ensign Equipment Inc. 12523 Superior Court Holland, MI 49424 ensigneq.com	Phone: 616-738-9000 Fax: 616-738-9001 Toll Free: 800-753-8947 sales@ensigneq.com
---	---