

**Ensign
Equipment
Inc.**

Hydraulic Box Dumper

The Hydraulic Box Dumper is a durable, well built unit designed for industrial applications. It features greaseable sleeve bearings at the main pivot and bronze sleeve bearings at the top cylinder mounts. We use a proven 1.5 h.p. hydraulic package with easy to service components and a separate oil reservoir.

Designed for increased safety, the unit features a wider clearance between the frame and bucket to reduce possible pinch points. The unit can be stopped anywhere in the up - down cycle simply by releasing the push button control.

Our standard units all have 2500# lift capacity and a gravity return. Units are powered by a pair of 2" bore, 2" rod, ram style cylinders. Special dust control and other hooded units use cylinders with a 3" bore and are powered on both the up and down cycles.



See back page for additional specifications.

All Ensign Equipment Inc. products carry a TWO YEAR warranty covering defects in manufacture, workmanship and components. Also all STANDARD products are covered by the Ensign Advantage, a 30 day trial period guaranteeing customer satisfaction!

Ensign Equipment Inc.

12523 Superior Court
Holland, MI 49424
ensigneq.com

Phone: 616-738-9000
Fax: 616-738-9001
Toll Free: 800-753-8947
sales@ensigneq.com

Hydraulic Box Dumper

Standard Features:

- Bucket Rotation 135 deg.
- Motor 1.5 h.p.
- NEMA 12 Electrical Enclosure
- Hydraulic Cylinders w/ 24" stroke, 2" bore, 2" rod
- Adjustable Retaining Bar 32" to 48"
- Up Cycle Complete, Limit Switch
- Down Cycle Flow Control Valve
- Cycle Time- 30 sec. Up, 15 sec. Down
- Greasable Sleeve Type Main Bearings
- Ensign Blue Epoxy

Optional Features:

- Gaylord Entry Guides
- Velocity Fuse, (catches bucket in case of hydraulic rupture)
- Custom Size and Shape Buckets
- Dust Hood with Discharge Hatch
- Dust Containment Doors on Bucket
- Dumper Stands 12" to 72"
- Floor Grate in Bucket
- Double Acting Hydraulics
- Explosion Proof Electrical
- Stainless Steel Chute Liner
- Stainless Steel Construction
- Custom Paints and Matching Colors

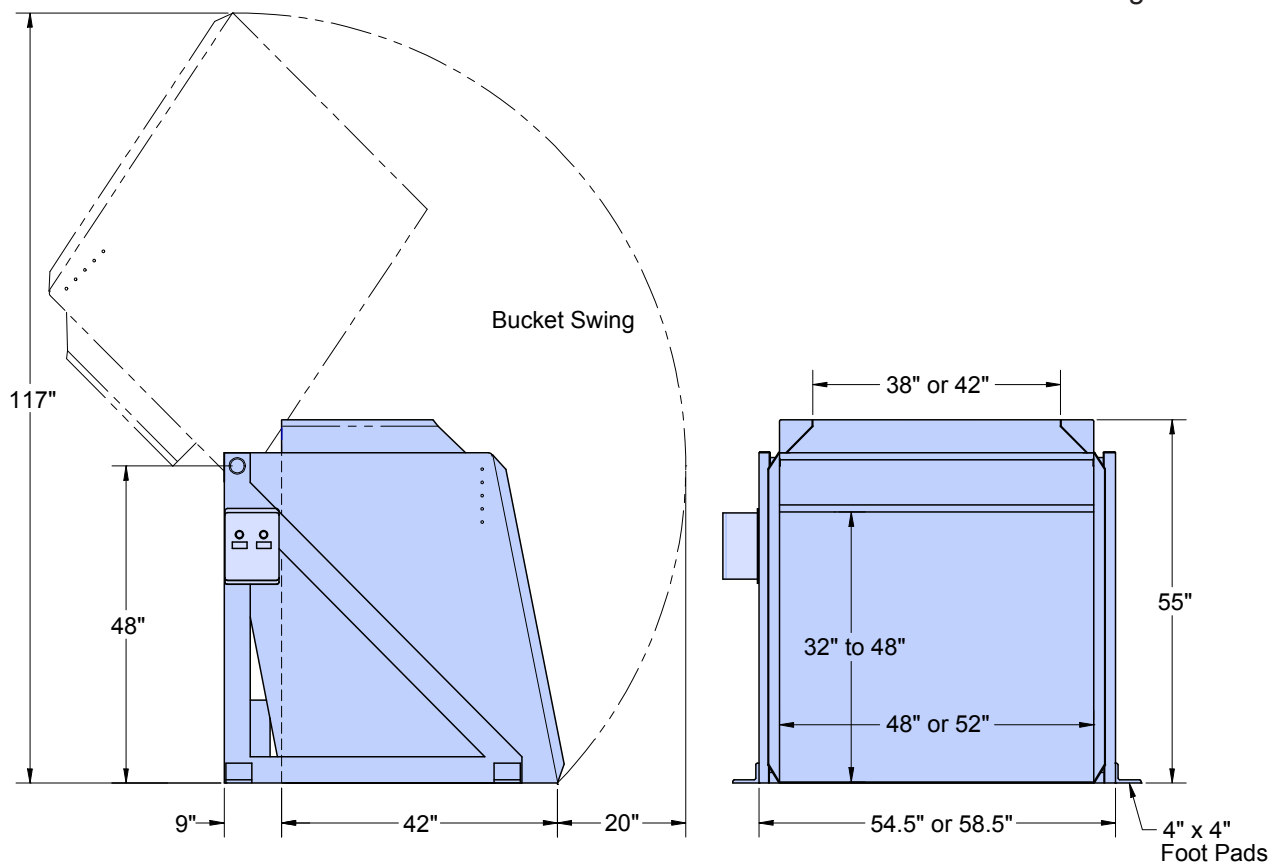

Model No.	Description
31-2500	Dumper, Rear Load, 2500 lbs, Cap., 3 Phase, 48" Wide Bucket
31-2550	Dumper, Rear Load, 2500 lbs. Cap., Single Phase, 48" Wide Bucket
31-5200	Dumper, Rear Load, 2500 lbs. Cap., 3 Phase, 52" Wide Bucket
31-5250	Dumper, Rear Load, 2500 lbs. Cap., Single Phase, 52" Wide Bucket

Ensign Equipment Inc.

12523 Superior Court
Holland, MI 49424
ensigneq.com

Phone: 616-738-9000
Fax: 616-738-9001
Toll Free: 800-753-8947
sales@ensigneq.com