

**Ensign
Equipment
Inc.**

Ground Entry *Pneumatic* Gaylord Tilter

Model 10-6000



The Ground Entry Pneumatic Gaylord Tilter is designed to assist in the vacuum unloading of gaylord containers. The automatic tilting feature allows complete removal of material from the container with little or no assistance from your operator. The adjustable regulator permits setting initial lift at any desired weight: this unit will lift 800# with only 80psi. air pressure! Normal operation is to begin tilting action when the box is around half empty. Ensign Equipment Inc. Tilt Tables are durable and easy to maintain. We use heavy duty pillow block bearings to ensure smooth controlled pivoting. Our seven gauge deck along with its sound structural design make it durable enough to withstand years of abuse. These units will reduce labor cost by freeing your operator from tending to raw material flow. They also reduce material waste with the effortless, complete emptying of your container!

All Ensign Equipment Inc. products carry a TWO YEAR warranty covering defects in manufacture, workmanship and components. Also all STANDARD products are covered by the Ensign Advantage, a 30 day trial period guaranteeing customer satisfaction!

Ensign Equipment Inc.

12523 Superior Court
Holland, MI 49424
ensigneq.com

Phone: 616-738-9000
Fax: 616-738-9001
Toll Free: 800-753-8947
sales@ensigneq.com

Ground Entry Gaylord Tilter

Standard Features:

- Automatic or Manual Tilt Action
- Hand Level Controlled
- Flow Control to adjust operating speed
- Seven Gauge Steel Deck
- Adjustable Height Vacuum Wand Holder
- 1" Pillow Block Pivot Bearing
- Double Convoluted Industrial Air Bag
- 45 Degree Tilt Angle
- Ensign Blue Epoxy

Optional Features:

- Foot Pedal Control Valve
- Pneumatic Turbine Vibrator w/ Controls
- 110V Electric Vibrator w/ Controls
- Custom Paints and Matching Colors

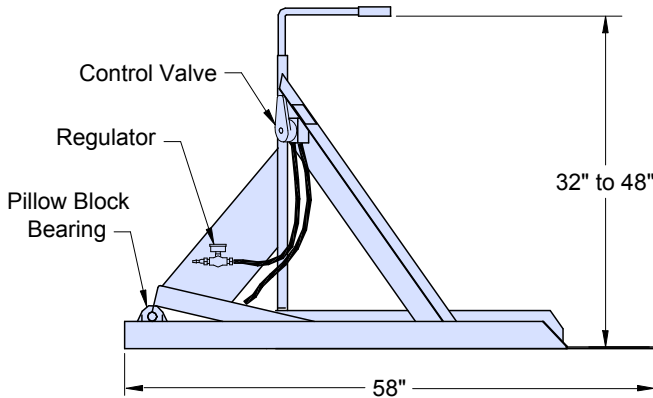
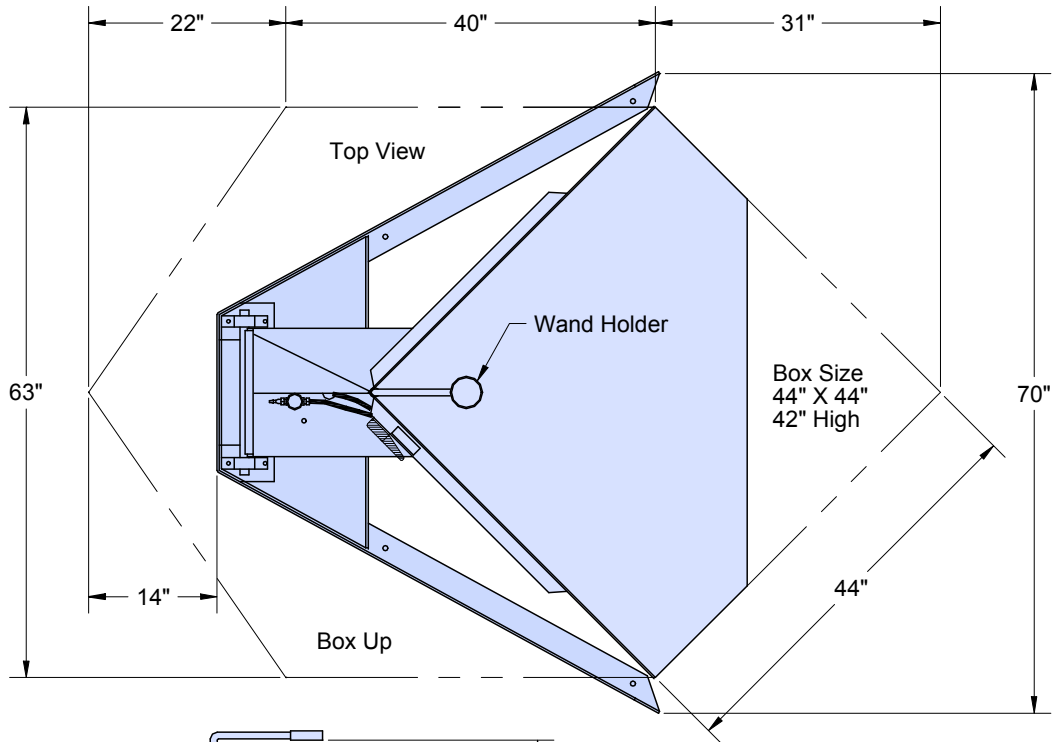

Lift Capacity Chart

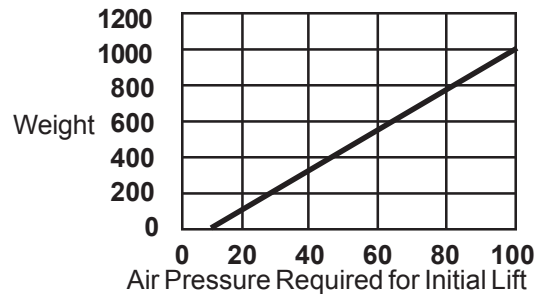

Ensign Equipment Inc.

12523 Superior Court
Holland, MI 49424
ensigneq.com

Phone: 616-738-9000
Fax: 616-738-9001
Toll Free: 800-753-8947
sales@ensigneq.com