

**Ensign  
Equipment  
Inc.**

# Bag Break Station



The Ensign Bag Break Stations are designed to feed bagged materials in to your bulk material handling system. Bag Break units are made in modular sections so you can pick the right components for your application. We have Dust Hoods that will support a self contained dust collecting unit or ones that can be connected to your in house dust system. Our hoppers sections can be adapted to screw conveyors or a variety of pneumatic systems. We also have bag compactors, grates and bag cutters to make the job go more easily.

Ensign Equipment Bag Break Stations are built to last with a heavy duty steel construction and quality components. Custom designed units available upon request. See back page for additional specifications.

All Ensign Equipment Inc. products carry a TWO YEAR warranty covering defects in manufacture, workmanship and components.



**Ensign Equipment Inc.**

12523 Superior Court  
Holland, MI 49424  
ensigneq.com

Phone: 616-738-9000  
Fax: 616-738-9001  
Toll Free: 800-753-8947  
sales@ensigneq.com

# Bag Break Station

## Hopper Features:

- 10 cu.ft. Hopper Capacity
- Hopper Dimension 40" x 40" x 36" high
- Bag Rest 5" x 40"
- Bag Breaker Grate
- Air Box Discharge Flange
- Ensign Blue Epoxy Paint

## Dust Hood Features:

- Hinged Cover
- Hood Dimension 40" x 40" x 20" high
- Dust Collector Mounting Flange, or Vent Stub for Existing Collector
- Gas Shock Cover Support
- Ensign Blue Epoxy

## Optional Features:

- Bag Compactor
- Dust Collector
- Vibrator
- Casters (2 swivel, 2 rigid locking)
- Air Box with 1-1/2" to 4" Probes
- Screw Conveyor Discharge
- Level Control Switch
- Stainless Steel Construction
- Custom Paints and Matching Colors



**Bag Break Station  
Dimensions**

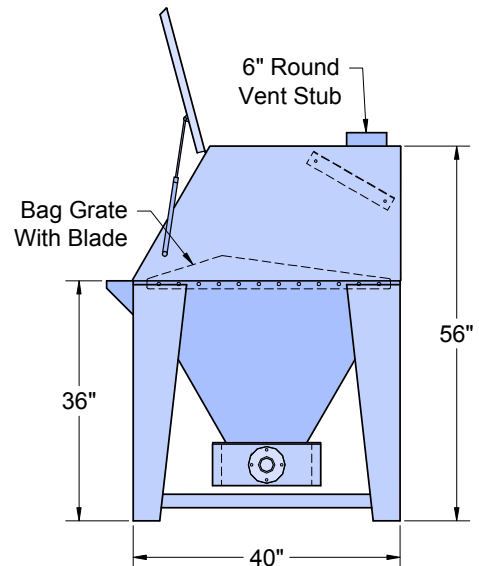
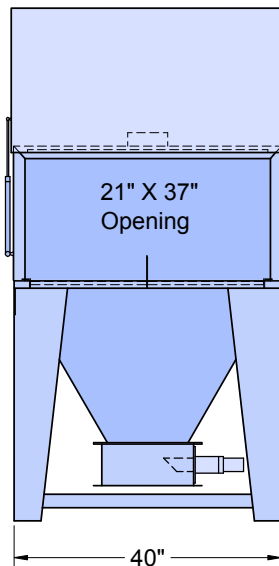

## Ensign Equipment Inc.

12523 Superior Court  
Holland, MI 49424  
ensigneq.com

Phone: 616-738-9000  
Fax: 616-738-9001  
Toll Free: 800-753-8947  
sales@ensigneq.com